



## DP3

Dual class-A preamp



Our flagship preamp, DP2, has been replaced by the all new DP3.

The DP3 is a unique hybrid design including both vintage and modern circuits.

The midrange crunch of the germanium sound of the mid 60's, the low mid punch and thick sound associated with British class-A from the early 70's as well as the more modern tone from the 80's and 90's.

It contains not just our well proven input stage and germanium circuit, we have also incorporated a new saturation circuit that together with the vintage class-A stage gives you lots of character choices.

The input stage is designed around a high quality Swedish Lundahl transformer and a hi-gain stage followed by selectable saturation and germanium circuits for more color and harmonics.

Instead of switching output stages as it was done in our previous models the class-A stage is now inserted in front of the output level control letting you drive the transformer harder without overloading your A/D converters. This also make the output less sensitive to different load impedance. The class-A stage uses a heavy custom made Carnhill transformer that produces a fat and punchy sound with mid-range character and a warm top end.

The Hi-Z instrument input has a separate activating switch so that you can let your instrument stay connected all the time. The Hi-Z direct mode function bypass the input transformer and input stage and send the instrument signal direct to the HPF and the selectable saturation and germanium circuits.

Direct mode gain is +14dB which is perfect for bass recording together with the class-A stage.

The sweepable HPF goes from 30Hz to 400Hz which allows precision crafting of the low end.

## Key Features:

- Hi-gain input stage with up to 80dB of gain
- Selectable vintage class-A stage
- Lundahl and Carnhill transformers
- Selectable germanium and saturation circuits for more color and harmonics
- Sweepable high-pass filter, 30-400Hz, 12dB/octave
- Instrument input with 2 Mohm impedance
- Output level placed after class-A stage
- Headroom meter with eight LED's

## Specifications:

Input impedance: 1600 ohm / 400 ohm

Instrument input impedance: 2 Mohm

Max output level: +26dBu

Balanced output impedance: 50ohm

DI-direct gain: +14dB

Frequency response electronic balanced: -0,2dB @ 80kHz

Frequency response class A inserted: -0,5dB @ 20kHz

THD+N @ +20dBu: 0,007%

THD+N @ +20dBu, class-A inserted: 0,01%

THD+N @ +20dBu, saturation stage active: >0,3%

THD+N @ +20dBu, germanium stage active: >1%

Power requirement: 115v or 230v internally selectable

Power consumption: 15VA

## Features:

Hi-Z input: High impedance instrument input with 2 Mohm input impedance

In: activates the instrument input

Direct: bypasses the mic input stage and feeds the Hi-Z input stage directly to the HPF

48v phantom power switch with separate LED indicator

Gain switch in 5dB steps: -25 to -80dB, +5dB to -25 with -30dB pad selected

Headroom meter: This LED-meter is a headroom meter and NOT a VU-meter. It is connected before the output level control to show the internal headroom even if you have lowered the output level. With the level at max the meter indicates clip at +25dB.

-30dB: pads the input signal -30dB (for best signal to noise ratio, avoid the 30dB pad if not needed)

Impedance: mic input impedance normally 1600ohm, 400ohm when engaged

Sweepable high pass filter: 30-400Hz, 12dB/octave

Saturation: inserts a saturation stage for extra harmonics after the HPF

Germanium: inserts a germanium stage after the HPF (for more color, select higher gain and back off a little with the output level control)

Selectable vintage class-A stage

Output level control: adjusts the output level after the class-A stage if inserted

Polarity switch: flips the output polarity

Illuminated switches (except for the phantom toggle switch which has a separate LED)

*Specifications and components may be changed or updated without further notice.*

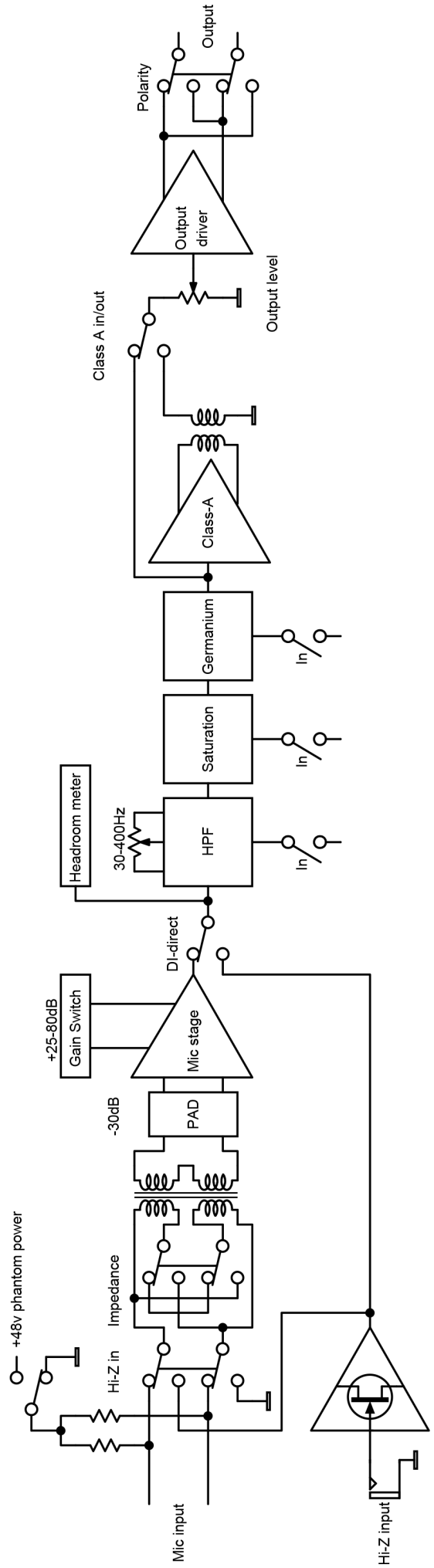

## EU - Declaration of conformity / Överensstämmelseintyg

### Product

DP3

115v - 200mA, anti surge fuse (slow)

230v - 100mA, anti surge fuse (slow)

### Manufacturer / Tillverkare

Musikverkstan i Halmstad AB / TK Audio

Falkenbergsgatan 10

30233 Halmstad

Sweden



Thomas Kristiansson, CEO

Halmstad, July 2024

### Declaration of conformity

I declare under my sole responsibility that this product, to which this declaration relates, is in conformity with the following standards:

EN55013, EN55020:2002, EN61000-3-2, EN61000-4-2 and EN60065

Following the provision of 73/23/EEC, 89/336/EEC and 93/68/EEC.

### Överensstämmelseintyg

Härmed intygas helt på eget ansvar att denna produkt, vilket detta intyg avser, uppfyller följande standarder:

EN55013, EN55020:2002, EN61000-3-2, EN61000-4-2 och EN60065

Följer reglerna 73/23/EEC, 89/336/EEC och 93/68/EEC